



higher education
& training

Department:
Higher Education and Training
REPUBLIC OF SOUTH AFRICA

NATIONAL CERTIFICATE

FITTING AND MACHINING THEORY N2

(11022032)

24 August 2021 (X-paper)
09:00–12:00

Drawing instruments and nonprogrammable calculators may be used.

This question paper consists of 9 pages and 1 formula sheet.

110Q1G2130

DEPARTMENT OF HIGHER EDUCATION AND TRAINING
REPUBLIC OF SOUTH AFRICA
NATIONAL CERTIFICATE
FITTING AND MACHINING THEORY N2
TIME: 3 HOURS
MARKS: 100

INSTRUCTIONS AND INFORMATION

1. Answer ALL the questions in SECTION A, except for QUESTION 1 where you must answer either QUESTION 1.1 **OR** QUESTION 1.2.
 2. Answer any TWO questions in SECTION B.
 3. Read all the questions carefully.
 4. Number the answers according to the numbering system used in this question paper.
 5. Start each section on a new page.
 6. Use only a black or blue pen.
 7. Write neatly and legibly.
-

SECTION A

Answer all the questions of either QUESTION 1.1 **OR** QUESTION 1.2 in SECTION A

QUESTION 1: OCCUPATIONAL SAFETY

1.1 Indicate whether the following statements are TRUE or FALSE by writing only 'True' or 'False' next to the question number (1.1.1–1.1.5) in the ANSWER BOOK.

- 1.1.1 The normal working pressure in a pneumatics system must be clearly indicated on the pressure gauge by means of a red line.
- 1.1.2 A machine should be stopped within 48 hours after a safety appliance (warning bell, emergency brake) fails and it poses a danger to those working in the area.
- 1.1.3 Overhead transmission belts that are within normal reach must be guarded.
- 1.1.4 All shafts and spindle ends within reach, which project more than quarter of its diameter must be completely enclosed.
- 1.1.5 Electrical switches must be labelled to indicate the machine or equipment that they control.

(5 × 1)

[5]

OR

1.2 Indicate whether the following statements are TRUE or FALSE by writing only 'True' or 'False' next to the question number (1.2.1–1.2.5) in the ANSWER BOOK.

- 1.2.1 First-aid certificates are renewable every three years.
- 1.2.2 On completion of an underground welding task, an examination must be carried out by a competent person to ensure that no fire will result.
- 1.2.3 No person shall work in any un-illuminated part of a mine unless they carry a light
- 1.2.4 Smoking is ONLY allowed in the lifting cage.
- 1.2.5 No person working near moving machinery shall wear loose outer clothing.

(5 × 1)

[5]

QUESTION 2: COUPLINGS

- 2.1 Explain the difference between a *coupling* and a *clutch*. (2)
- 2.2 Name TWO different types of flexible couplings. (2)
- 2.3 Name TWO types of coupling misalignment. (2)
- [6]**

QUESTION 3 LIMITS AND FITS

- 3.1 Choose a description from COLUMN B that matches a term in COLUMN A. Write only the letter (A–C) next to the question number (3.1.1–3.1.3) in the ANSWER BOOK.

COLUMN A		COLUMN B	
3.1.1	Clearance fit <input checked="" type="radio"/>	A	the diameter of the shaft may be slightly larger than the diameter of the hole, and still be within the limits
3.1.2	Transition fit	B	the diameter of the shaft is always made larger than the diameter of the hole
3.1.3	Interference fit	C	the diameter of the shaft is always made smaller than the diameter of the hole

(3 × 1) (3)

- 3.2 A shaft must have a slide fit into a bush. The dimensions of the hole and shaft are as follows:

$$\text{SHAFT: } \phi 35_{-0.00\text{mm}}^{-0.03\text{mm}}$$

$$\text{BUSH: } \phi 35_{+0.02\text{mm}}^{+0.06\text{mm}}$$

- 3.2.1 Name the type of tolerance applicable for the bush.
- 3.2.2 Name the type of tolerance applicable for the shaft.
- 3.2.3 Calculate the tolerance on the shaft. (4)
- 3.2.4 Calculate the tolerance on the bush. (4 × 1) **[7]**

QUESTION 4: BEARINGS

4.1 FIGURE 1 shows a type of bearing. Name the parts labelled (A–C). Write only the answer next to the letter (A–C) in the ANSWER BOOK.



FIGURE 1

(3)

4.2 Name TWO reasons why plain bearings fail.



(2)
[5]

QUESTION 5: LUBRICATION AND VALVES

5.1 Name the THREE main types of lubricants.

(3)

5.2 Explain the working principle of a ball valve.



(3)
[6]

QUESTION 6: PACKING, STUFFING BOXES, JOINTS AND WATER-PIPE SYSTEMS

6.1 State ONE function of the packing and seals

(1)

6.2 State FIVE important guidelines to ensure the proper fitting of O-rings and seals in hydraulic systems.



(5)

6.3 Name the THREE types of pipe fittings shown in FIGURE 2 below. Write only the answer next to the question number (6.3.1–6.3.3) in the ANSWER BOOK.

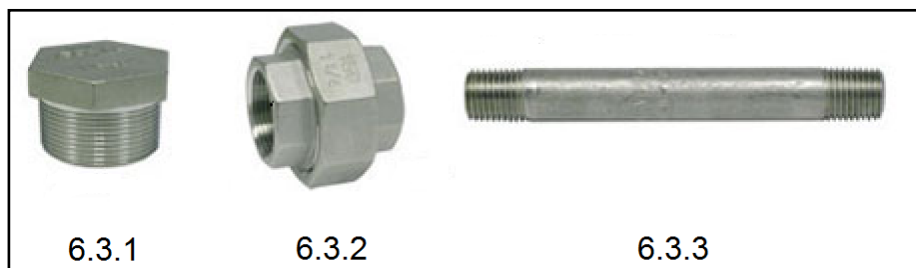

FIGURE 2

(3)
[9]

QUESTION 7: PUMPS

- 7.1 Name any TWO basic components that centrifugal pumps consist of. (2)
- 7.2 Explain the working principle of a single acting reciprocating pump. (2)
- 7.3 Distinguish between a *positive displacement pump* and a *non-positive displacement pump*. (2)
- [6]**

QUESTION 8: COMPRESSORS

- 8.1 Name THREE types of rotary compressors. (3)
- 8.2 State the SI unit for pressure. (1)
- [4]**

QUESTION 9: V-BELT, GEAR DRIVES, CHAIN DRIVES AND REDUCTION GEARBOXES

- 9.1 Name THREE types of sprockets associated with chain drives. (3)
- 9.2 Explain the following concepts with regard to gear drives:
- 9.2.1 Velocity ratio (2)
- 9.2.2 Mechanical advantage (2 × 1) (2)
- 9.3 State FOUR advantages that V- belt drives have over chain drives. (4)
- 9.4 Name THREE types of reduction gearboxes used in industry. (3)
- [12]**

TOTAL SECTION A: 60

SECTION B

NOTE: Answer only TWO questions in SECTION B.

QUESTION 10: HYDRAULICS AND PNEUMATICS

- 10.1 Name THREE basic components used in a hydraulic system. (3)
- 10.2 List THREE main functions of oil in a hydraulic flow system. (3)
- 10.3 FIGURE 3 below shows a hydraulic circuit. Name the parts labelled (A–E). Write only the answer next to the letter (A–E) in the ANSWER BOOK.

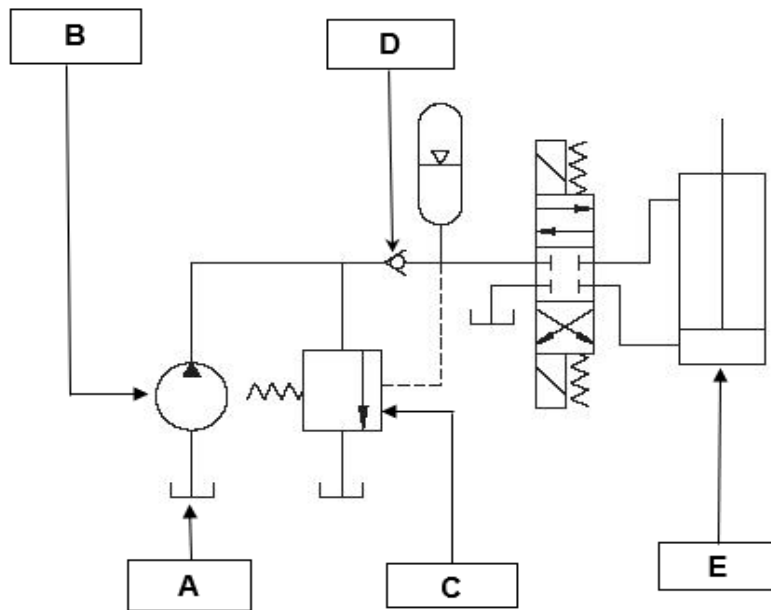

FIGURE 3

(5 × 1) (5)

- 10.4 State five factors that influence the choice of pneumatics over hydraulics for transmitting power to machines. (5)
- 10.5 Explain the function of a pressure relief valve in a hydraulic system. (1)
- 10.6 List THREE checks to be done on hoses when maintaining a pneumatic system. (3)

[20]

QUESTION 11: CENTRE LATHES

11.1 State THREE uses of lathe steadies. (3)

11.2 A spindle is to be turned to the dimensions given in FIGURE 4 below:

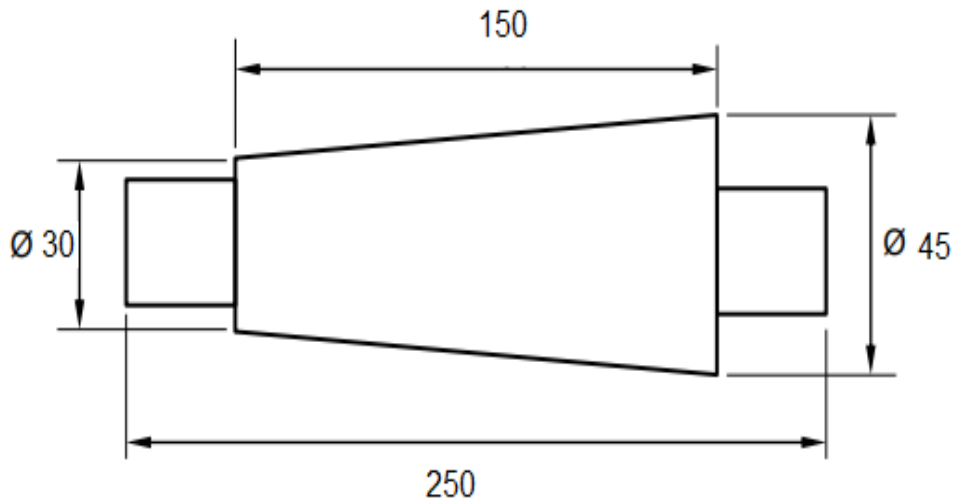

FIGURE 4

11.2.1 Calculate the amount of tailstock set-over. (2)

11.2.2 Calculate the included angle of the tapered portion. Write the answer in degrees and minutes. (3)

11.3 A carbon steel pin is to be finished on a centre lathe. The cutting speed for carbon steel is 56,55 m/min.

Calculate the diameter of the carbon if the spindle speed setting is 1 800 r/min. (3)

11.4 A work piece is to be machined on a centre lathe. The length of the cut on the work piece is 250 mm. The lathe feed is set at 0,5 mm/rev. The spindle speed is 199 r/min.

Calculate the time taken, in minutes and seconds, to make one longitudinal cut on the work piece. (3)

11.5 A two-start square thread of 12 mm pitch has to be machine on a round shaft with an outside diameter of 66 mm. Take the clearance angle as 3°.

Calculate:

11.5.1 The helix angle (θ) of the thread. (4)

11.5.2 The lead angle of the cutting tool. (1)

11.5.3 The following angle the cutting tool. (1)

[20]

QUESTION 12: MILLING MACHINES AND SURFACES GRINDERS

12.1 FIGURE 5 below shows two milling processes.

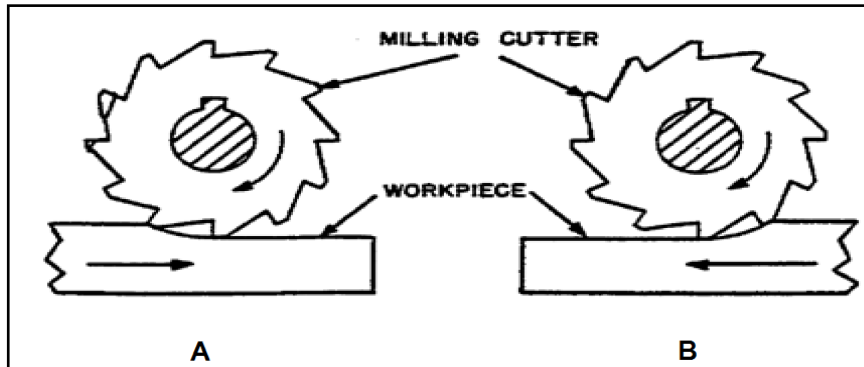

FIGURE 5

12.1.1 Name the TWO milling processes marked A and B in FIGURE 5.

12.1.2 Give ONE reason for EACH of your answers in QUESTION 12.1.1.

12.1.3 State TWO disadvantages of milling process A.

12.1.4 State TWO advantages of milling process B

(4 × 2) (8)

12.2 A milling machine is used to cut NINE evenly spaced grooves around a shaft.

Calculate the required indexing using the Brown and Sharp dividing head.

THE BROWN AND SHARP DIVIDING HEAD						
Number of holes						
Plate 1	15	16	17	18	19	20
Plate 2	21	23	27	29	31	33
Plate 3	37	39	41	43	47	49

(5)

12.3 List FIVE reasons for the use of small diameter cutters.

(5)

12.4 Name the abrasive material used to grind each of the following:

12.4.1 Carbon steel

12.4.2 Soft bronze

(2 × 1) (2) [20]

TOTAL SECTION B: 40
GRAND TOTAL: 100

FORMULA SHEET

FITTING AND MACHINING THEORY N2

1. $f = f_t \times T \times N$

2. $S = \frac{\pi DN}{60}$

3. $S = \pi DN$

4. $\frac{40}{N}$

5. $\frac{N}{9^\circ}$

6. $\text{Set-over} = \frac{D-d}{2} \times \frac{\text{length of workpiece}}{\text{length of taper}}$

7. $\tan \frac{\theta}{2} = \frac{X}{L}$

8. $\text{Leading angle} = 90^\circ - (\text{helix angle} + \text{clearance angle})$

9. $\text{Following angle} = 90^\circ + (\text{helix angle} - \text{clearance angle})$

10. $\text{Lead} = \text{number of starts} \times \text{pitch}$