



**higher education  
& training**

---

Department:  
Higher Education and Training  
**REPUBLIC OF SOUTH AFRICA**

**NATIONAL CERTIFICATE  
MECHANOTECHNOLOGY N3**

(8190373)

**25 August 2021 (X-paper)  
09:00–12:00**

**This question paper consists of 7 pages, 2 tables and 1 formula sheet.**

142Q1G2102

**DEPARTMENT OF HIGHER EDUCATION AND TRAINING**  
**REPUBLIC OF SOUTH AFRICA**  
NATIONAL CERTIFICATE  
MECHANOTECHNOLOGY N3  
TIME: 3 HOURS  
MARKS: 100

---

**INSTRUCTIONS AND INFORMATION**

1. Answer all the questions.
  2. Read all the questions carefully.
  3. Number the answers according to the numbering system used in this question paper.
  4. Start each question on a new page.
  5. Use only black or blue pen.
  6. Write neatly and legibly.
-

**QUESTION 1: POWER TRANSMISSION, CLUTCHES AND COUPLING OF SHAFTS**

1.1 A 16N SPB wedge belt is fitted between an electrical motor and a hammer mill.

The following information is given:

Design power of the electric motor	60 kW
Correction factor	0,9
Service factor	1,2
Type of start	'soft'
Basic power per belt	22 kW
Power increment/additional power per belt	2 kW
Type of duty operation	'medium'
Operational hours per duty shift	9 hours
Speed of the electric motor	1400 r/min

Calculate the following:

1.1.1 The power of the electric motor. (2)

1.1.2 Corrected power per belt.  (3)

1.1.3 The number of belts driving the mill. (3)

1.2 Couplings are classified into 3 groups. Name them  (3)

1.3 Refer to FIGURE 1 below of a gear tooth terms and label the different parts (A–E), as indicated. Write only the answers next to the letter (A–E) in the ANSWER BOOK.

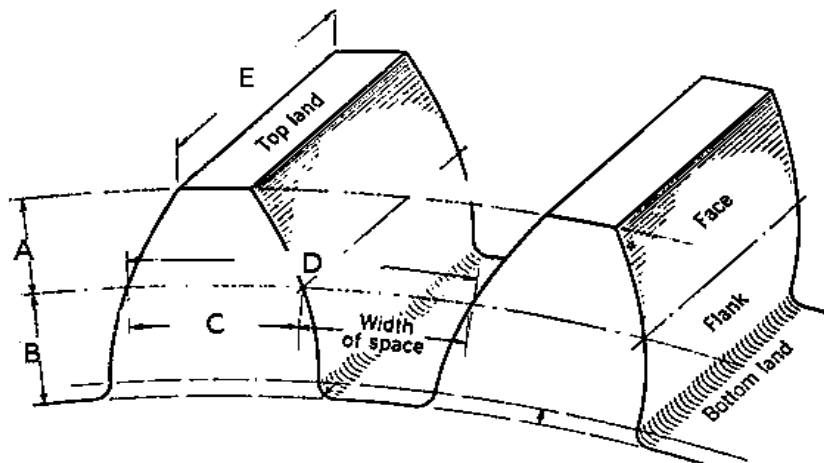

**FIGURE 1**

(5)

- 1.4  Refer to FIGURE 2 (below) of a multi-disc clutch and label the different parts (A–C), as indicated. Write only the answers next to the letter (A–C) in the ANSWER BOOK:

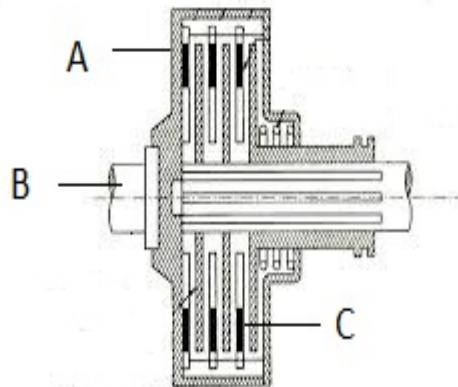

**FIGURE 2**

(3)  
[19]

**QUESTION 2: BRAKES**

- 2.1 A brake is a device operated by electromagnetic, hydraulic, air-pressure, mechanical means.   
State FOUR functions of a brake in a vehicle or machine. (4)
- 2.2 Give TWO advantages of electromagnetic braking system (2)  
[6]

**QUESTION 3: BEARINGS**

- 3.1 Name THREE types of loads applicable to anti-friction bearings. (3)
- 3.2 Name FIVE types of friction bearings.  (5)  
[8]

**QUESTION 4: WATER PUMPS, COOLING AND LUBRICATION**

- 4.1 Indicate whether the following statements are TRUE or FALSE by writing only 'True' or 'False' next to the question number (4.1.1–4.1.6) in the ANSWER BOOK. Give ONE reason for each answer.
- 4.1.1 In a piston pump the length of a piston is longer than its stroke.
- 4.1.2 For external packing in a plunger or piston pump, it is possible to replace or adjust the packing without opening the pump.
- 4.1.3 Pumps with internal packing are suitable only for pure clean fluids under medium pressure
- 4.1.4 The collision of water within a pipe may cause 'water hammer'
- 4.1.5 Centrifugal pumps are suitable for pumping heavy gas.
- 4.1.6 Another term for flood suction is negative head (6 × 1) (6)
- 4.2 Give THREE reasons why it is necessary for a welding machine to be kept cool.  (3)
- 4.3 Apart from the use of an oil can or grease pot to lubricate machinery, list FIVE other methods that can be used to apply lubrication on machine parts and components. (5)  
[14]

**QUESTION 5: HYDRAULICS AND PNEUMATICS**

- 5.1 A ram of a hydraulic press can exert a force of 13 000 N if a force of 250 N is exerted on a piston.
- If the diameter of the piston is 70 mm calculate the following:
- 5.1.1 The diameter of the ram in mm. Round your answer to THREE decimal places  (4)
- 5.1.2 The pressure in the fluid in kPa. (3)
- 5.2 Make neat drawings of the ISO symbols as applicable to pneumatic systems of the following:
- 5.2.1 A compressor
- 5.2.2 A filter
- 5.2.3 A pressure gauge
- 5.2.4 A lubricator (4 × 1) (4)  
[11]

**QUESTION 6: INTERNAL COMBUSTION ENGINE**

6.1  Label the different parts of a carburettor (A–C) in FIGURE 3 below. Write the only the answers next to the letter (A–C) in the ANSWER BOOK.

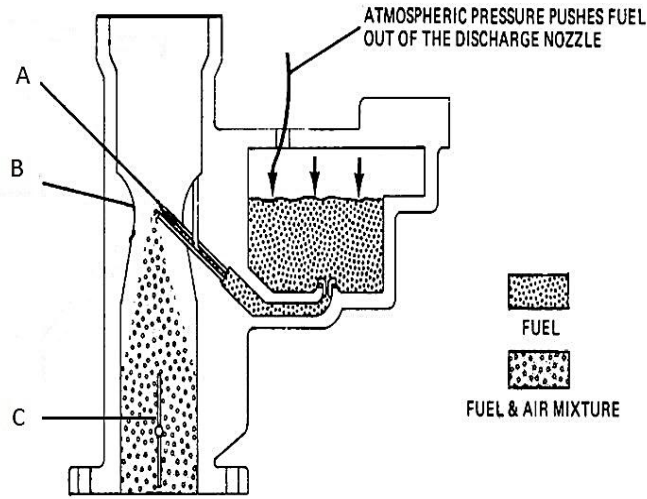

**FIGURE 3**

(3)

6.2 Define the term *compression ratio*, in reference to internal combustion engines.

(2)  
[5]

**QUESTION 7: CRANES AND LIFTING MACHINES**

7.1 Briefly describe THREE advantages of the infrared signal remote control when compared to the driver's cabin on the overhead crane.

(3)

7.2 Label the different parts of a tower crane mounted on a bogie (A–E) in FIGURE 4 below. Write only the answers next to the letter (A–E) in the ANSWER BOOK.

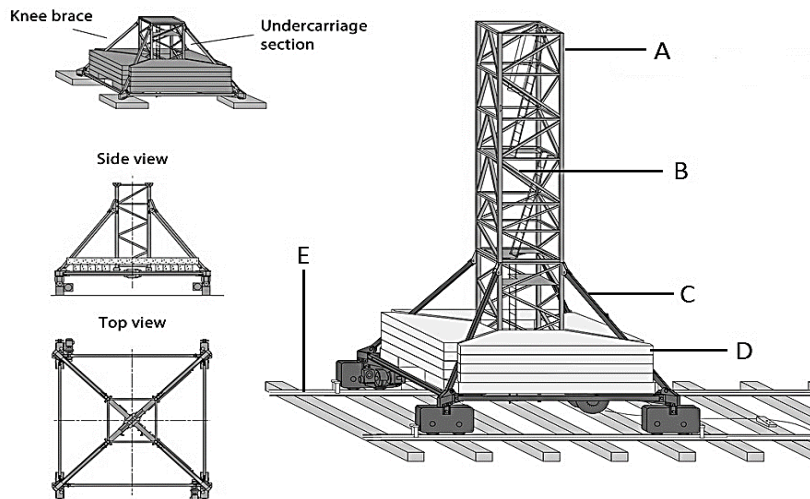

**FIGURE 4**

(5)  
[8]

**QUESTION 8: MATERIAL AND MATERIAL PROCESSES**

- 8.1 Indicate whether the following statements are TRUE or FALSE by writing only 'True' or 'False' next to the question number (8.1.1–8.1.2) in the ANSWER BOOK.
- 8.1.1 Durability can be considered as a characteristic of thermosetting plastics.
- 8.1.2 As a property of metal, elasticity is the ability of a metal to deform under load and then return to its original shape.  (2 × 1) (2)
- 8.2 Explain what is meant by *tensile strength* as a property of metal. (2)
- 8.3 State FOUR properties of thermosetting plastics (4)  
**[8]**

**QUESTION 9: INDUSTRIAL ORGANISATION AND PLANNING**

- 9.1 List FIVE listening skills that can improve the effectiveness of the communication process.  (5)
- 9.2 Upward communication is the flow of information from subordinates to management.  
Give FIVE reasons why management relies on upward communication. (5)
- 9.3 Briefly explain what is meant by diagonal communication. (2)  
**[12]**

**QUESTION 10: ENTREPRENEURSHIP**

- 10.1 List SIX basic qualities that an entrepreneur should have in order to stand a chance in the small business enterprise.  (6)
- 10.2 Briefly describe the term service business as a business opportunity for a small business enterprise sector. (3)  
**[9]**

**TOTAL: 100**

**TABLE 1****SERVICE FACTORS FOR THE SELECTION OF WEDGE BELTS**

<b>TYPES OF DRIVEN MACHINES</b>	<b>TYPES OF PRIME MOVERS</b>					
	<b>'Soft' starts</b>			<b>'Heavy' starts</b>		
	<b>Hours per day duty</b>			<b>Hours per day duty</b>		
	<b>10 and under</b>	<b>Over 10 to 16</b>	<b>Over 16</b>	<b>10 and under</b>	<b>Over 10 to 16</b>	<b>Over 16</b>
Class 1 – Light duty Blowers and fans Centrifugal compressors and pumps Belt conveyors (uniformly loaded)	1,0	1,1	1,2	1,1	1,2	1,3
Class 2 – Medium duty Blowers and fans Rotary compressors and pumps Belt conveyors (not uniformly loaded) Generators	1,1	1,2	1,3	1,2	1,3	1,4
Class 3 – Heavy duty Brick machinery Compressors and pumps (reciprocating) Conveyors (heavy duty) Hammer mills Punches and presses	1,2	1,3	1,4	1,4	1,5	1,6
Class 4 – Extra heavy duty Crushers Mills	1,3	1,4	1,5	1,5	1,6	1,8



**TABLE 2****MINIMUM PULLEY DIAMETER (mm)**

Speeds of faster than in r/min	Minimum pulley diameter (mm)																			
	Design power (kW)																			
	To 1	3,0	4,0	5,0	7,5	10	15	20	25	30	40	50	60	75	90	110	130	150	200	250
<b>500</b>	67	90	100	112	125	140	180	200	212	236	250	280	280	315	375	400	450	475	500	560
<b>600</b>	67	85	90	100	112	125	140	180	200	212	224	250	265	280	300	335	375	400	475	500
<b>720</b>	67	80	85	90	90	106	132	150	160	170	200	236	250	265	280	300	335	375	450	500
<b>960</b>	67	75	80	85	95	100	112	132	150	180	180	200	224	250	280	280	300	335	400	450
<b>1 200</b>	67	71	80	80	95	95	106	118	132	150	160	180	200	236	236	250	265	300	335	355
<b>1 440</b>	67	67	75	80	85	85	100	112	125	140	160	170	190	212	236	236	250	280	315	335
<b>1 800</b>	67	67	71	75	80	85	95	106	112	125	150	160	170	190	212	224	236	265	300	335
<b>2 800</b>	67	67	67	67	80	80	85	90	100	112	125	140	160	170	180	212	224	236	-	-

(8190373)

## **MECHANOTECHNOLOGY N3**

### **FORMULA SHEET**

Any applicable formula may also be used.

1. *Corrected power per belt = (basic power per belt + power increment per belt) × correction factor*
2. *Force (F) = Pressure (P) × Area (A)*
3. *Work done (W) = Force (F) × Distance (s)*
4. *Volume (V) = Area of base (A) × Perpendicular height ( $\perp h$ )*